



# LIQUID CONTROLS

Simply the Best™



## MS-Series Positive Displacement Flow Meters

Liquid Controls steel-case MS-Series rotary motion positive displacement (PD) meters offer the ultimate in flow measurement accuracy for bulk custody transfer of petroleum products, aviation fuels, LPG, crude oil, petrochemicals, and a broad range of industrial liquids. MS-Series meters incorporate a unique design, presenting minimal intrusion in a flowing stream of liquid, as well as minimal pressure drop through the meter.

Liquid Controls MS-Series meters consist of an outer spherical steel-case shell with flanged inlet and outlet ports. The shell houses a traditional LC metering element that employs three rotating and synchronized rotors. These rotors accurately segment flow into a precise volume of liquid for each revolution, with no metal-to-metal contact inside the measuring chamber. Hydraulic sealing between the rotors and the measuring chamber wall is accomplished by a stationary boundary layer of liquid—not by the wiping action of mechanical parts—thereby ensuring **sustained accuracy, long service life** with minimal wear, and **low pressure drop** suitable for operation on gravity flow or pump pressure.

All MS-Series spherical shells are constructed of steel or stainless steel. Epoxy coated versions are available for aviation applications. Metering elements are available in metallurgies and seal materials suitable for a wide range of petroleum, petrochemical, and industrial applications.

### Accessories

MS-Series meters are available with a selection of bolt-on strainers and air eliminators for the inlet side, and a selection of manual or solenoid actuated valves for the meter outlet. Mechanical and electronic registration equipment and printers are also available. Contact factory for details.

### Industries served

LC MS-Series meters are well-suited for metering products requiring precise flow measurement and reliable, extended service life, including:

- Refined petroleum
- Fuel oil
- Aviation fuel
- LPG
- Alcohols, glycols, methanol
- Crude oil
- Petrochemicals
- Others



*Liquid Controls' unique measuring chamber with no metal-to-metal contact minimizes wear and ensures precise and consistent measurements over a long service life.*



## Mounting and accessory arrangements

### Mounting configurations

LC steel-case MS-Series meters may be mounted in a variety of configurations, as shown to the right.

*Note: regardless of meter mounting configuration, accessories such as the air/vapor eliminator must always be mounted in a vertical orientation to permit proper operation of the float-actuated apparatus.*

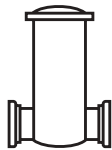
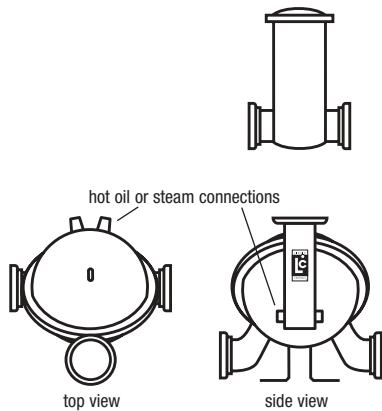

### Standard variations for register mounting flange (straight-through flow)

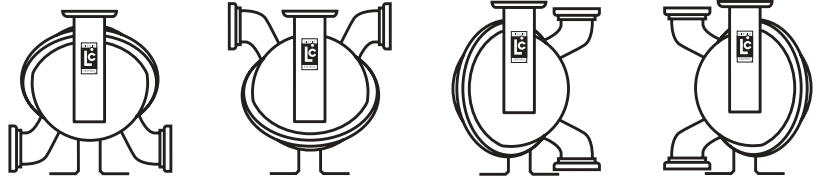

### Special variations for flanged spools

Note: Additional variations are possible (contact factory for details).

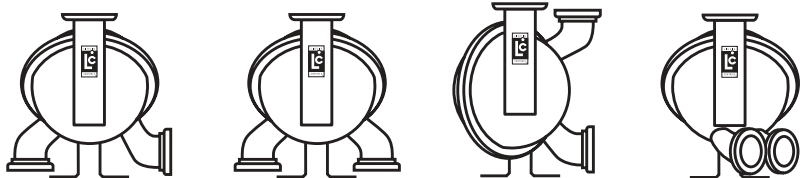

### Strainer

Available with 20, 40, 80, 100, or 200 mesh basket. In-line inlet/outlet shown. Units also available with bottom inlet.

### Hot oil/steam jacketed meter

Heating a meter can be accomplished by hot oil/steam jacketing the meter's rear cover and/or packing gland boss, or both. A heat jacketed meter does not preclude the necessity for insulating the meter and surrounding piping.

### Counter extensions

Counter extensions are typically used for the following reasons:

- In heated applications to protect the register components from excessive heat.
- To elevate the register stack for better visibility.

### Air eliminator

Float activated reed valve design offers low maintenance with no complicated linkages or valving mechanism. Effectively eliminates air or vapor before liquid enters meter. Must be installed so that ports are horizontal.

### Valve

Mechanically or electrically operated positive shutoff valves available. Contact factory for details.

### Counters, printers, presets, temperature volume compensators (TVCs) and Pulse Output Device (POD) pulsers

Mechanical or electronic counters, printers, presets and TVCs available. Also, electronic POD pulsers for converting the rotary motion of the LC meter into electronic pulses. Contact factory for details.

# Performance Specifications

Liquid Controls steel-case MS-Series positive displacement meters are engineered to provide accurate flow measurement and a long, trouble-free service life requiring minimal maintenance with few replacement parts.

The unique construction of these meters results in low pressure drop for most liquids, delivering superior performance and minimal demand on system pumps. The exclusive LC metering element eliminates inaccuracies due to clearance changes and maximizes life by minimizing loads on bearings and eliminating axial thrust. MS-Series meters' multiple inlet/outlet flange configurations (see mounting configurations diagram) provide unmatched mounting versatility and equal accuracy for forward or reverse flow.

LC meters meet NTEP (NIST Handbook 44) and International Weights and Measures accuracy requirements as well as U.S. Military specifications.



## Accuracy/Performance<sup>a</sup>

### Repeatability

Mech. registration: capable of 0.05% of reading over entire range  
Elect. registration: capable of 0.03% of reading over entire range

### Linearity

- Over 5:1 range  
Mech. registration: capable of  $\pm 0.125\%$  or better from max. nom. flow rate  
Elect. registration: capable of  $\pm 0.10\%$  or better from max. nom. flow rate
- Over 10:1 range  
Mech. registration: capable of  $\pm 0.22\%$  or better from max. nom. flow rate  
Elect. registration: capable of  $\pm 0.10\%$  or better from max. nom. flow rate
- Over 40:1 range  
Mech. registration: capable of  $\pm 0.5\%$  or better from max. nom. flow rate  
Elect. registration: capable of  $\pm 0.15\%$  or better from max. nom. flow rate

### Temperature range

-40° F to 160° F (-40° C to 71° C)  
For higher temperature applications, consult factory.

<sup>a</sup> Stated accuracy obtainable when all variables remain constant. Reading/measurements reflect a minimum of one minute of flow at selected rate(s). All accuracy statements based on metering safety solvent (aliphatic hydrocarbon), approximate viscosity 1 CPS. On higher viscosity products, the average deviation in accuracy will be less.

## Construction

### Meter housing

Steel or stainless steel (epoxy coated steel available for aviation and other applications)

### Meter element and rotors

Cast aluminum (other metalurgies available including cast iron and stainless steel)

### Internal components

Aluminum, Ni-Resist, stainless steel, iron

### Seal materials

UL recognized component: Buna-N, Viton<sup>®</sup>, Teflon<sup>®</sup>

### Bearings

Carbon, Teflon<sup>®</sup>, Ni-Resist, ceramic (MS-30 only)

Model	Flange size	Max. nom. flow rate	Working pressure <sup>b</sup>	Net weight
MS-7 <sup>®</sup>	2"	100 GPM 380 L/min	150 PSI 10.5 BAR	95 lbs 43 kg
MSAA-7 <sup>®</sup>	2"	100 GPM 380 L/min	285 PSI 19 BAR	134 lbs 60.8 kg
MSA-7 <sup>®</sup>	2"	100 GPM 380 L/min	300 PSI 21 BAR	151 lbs 68.5 kg
MS-15 <sup>®</sup>	3"	200 GPM 760 L/min	150 PSI 10.5 BAR	111 lbs 50.35 kg
MSAA-15 <sup>®</sup>	3"	200 GPM 760 L/min	285 PSI 19 BAR	181 lbs 82.1 kg
MSA-15 <sup>®</sup>	3"	200 GPM 760 L/min	300 PSI 21 BAR	111 lbs 50.35 kg
MS-30 <sup>®</sup>	3"	350 GPM 1325 L/min	150 PSI 10.5 BAR	135 lbs 61.24 kg
MSAA-30 <sup>®</sup>	3"	350 GPM 1325 L/min	285 PSI 19 BAR	220 lbs 99.9 kg
MSA-30 <sup>®</sup>	3"	350 GPM 1325 L/min	300 PSI 21 BAR	135 lbs 61.24 kg
MS-40 <sup>®</sup>	3"	450 GPM 1700 L/min	150 PSI 10.5 BAR	135 lbs 61.24 kg
MS-75 <sup>®</sup>	4"	700 GPM 2650 L/min	150 PSI 10.5 BAR	385 lbs 174.64 kg
MSAA-75 <sup>®</sup>	4"	700 GPM 2650 L/min	285 PSI 19 BAR	385 lbs 174.64 kg
MSA-75 <sup>®</sup>	4"	700 GPM 2650 L/min	300 PSI 21 BAR	385 lbs 174.64 kg
MS-120 <sup>®</sup>	6" or 8"	1200 GPM <sup>d</sup> 3785 L/min	150 PSI 10.5 BAR	490 lbs 222.26 kg
MSAA-120 <sup>®</sup>	6" or 8"	1200 GPM <sup>d</sup> 3785 L/min	285 PSI 19 BAR	785 lbs 356 kg
MSA-120 <sup>®</sup>	6" or 8"	1200 GPM <sup>d</sup> 3785 L/min	300 PSI 21 BAR	490 lbs 222.26 kg

<sup>b</sup> Models available with maximum working pressures of 720 PSI (model MSB) and 1440 psi (model MSC). Consult factory for details.

<sup>c</sup> Added-height counter extensions are available. Consult factory for details.

<sup>d</sup> 1200 GPM rating applies to meters supplied with 8" flanges; rating is 1000 GPM for meters with 6" flanges.

Viton<sup>®</sup> and Teflon<sup>®</sup> are registered trademarks of DuPont Corporation.  
Vicaltic<sup>®</sup> is a registered trademark of Vicaltic Company.

## Dimensions: steel case flow meters

Note: Dimensions shown are not for construction use. Consult factory when certified engineering prints are required.  
Additional inlet/outlet configurations available. See mounting configurations diagram for details.

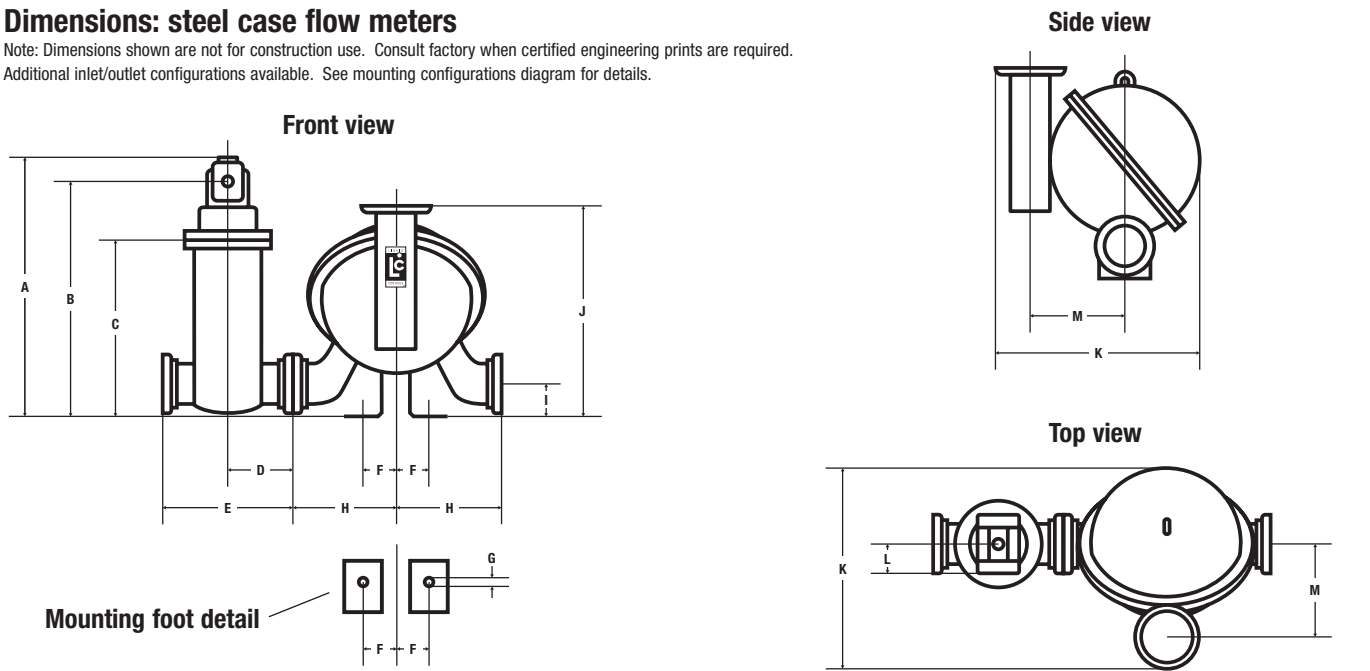

Dimensions	A	B	C	D	E	F	G	H	I	J <sup>c</sup>	K	L	M
in	26.9	24.1	17.6	7	14	3.5	.75	8.5	3.5	15.3	15.3	3.3	6.8
mm	683	612	447	178	356	89	19	216	89	389	389	84	173
in	26.9	24.1	17.6	7	14	3.5	.75	8.5	3.5	15.3	15.3	3.3	6.8
mm	683	612	447	178	356	89	19	216	89	389	389	84	173
in	25.9	23.1	16.6	7	14	3.5	.75	8.5	3.4	15.3	15.7	3.3	6.8
mm	658	587	422	178	356	89	19	216	89	389	398	84	173
in	27.8	24.9	18.5	7	14	3.5	.75	11	4.1	18	18.7	3.3	8.3
mm	706	632	470	178	356	89	19	279	104	457	475	34	211
in	27.8	24.9	18.5	7	14	3.5	.75	11	4.1	18	18.7	3.3	8.3
mm	706	632	470	178	356	89	19	279	104	457	475	34	211
in	26.7	23.9	17.4	7	14	3.5	.75	9.8	4.1	18	18.7	3.3	8.3
mm	678	607	442	178	356	89	19	249	104	457	475	34	211
in	27.8	25	18.5	7	14	3.5	.75	11	4.2	27.1	22.1	3.3	10
mm	706	635	470	178	356	89	19	279	107	688	561	34	254
in	27.8	25	18.5	7	14	3.5	.75	11	4.2	27.1	22.1	3.3	10
mm	706	635	470	178	356	89	19	279	107	688	561	34	254
in	26.7	23.9	17.4	7	14	3.5	.75	11.8	4.2	27.1	22.1	3.3	10
mm	678	607	442	178	356	89	19	300	107	688	561	34	254
in	27.8	25	18.5	7	14	3.5	.75	11	4.2	27.1	22.1	3.3	10
mm	706	635	470	178	356	89	19	279	107	688	561	34	254
in	30	27.2	20.7	7	14	5.3	.75	13.03	5.8	31.4	28.2	3.3	13.2
mm	762	691	526	178	356	135	19	331	147	798	716	34	335
in	30	27.2	20.7	7	14	5.3	.75	13.03	5.8	31.4	28.2	3.3	13.2
mm	762	691	526	178	356	135	19	331	147	798	716	34	335
in	28.3	25.5	19	7	14	5.3	.75	13.03	5.8	31.4	282	3.3	13.2
mm	719	648	483	178	356	135	19	331	147	798	716	34	335
in	36.5	33.7	27.1	10.5	21	6.5	1	17	7	34.9	31.6	3.3	14.7
mm	927	856	688	267	533	165	25	432	178	886	803	34	373
in	36.5	33.7	27.1	10.5	21	6.5	1	17	7	34.9	31.6	3.3	14.7
mm	927	856	688	267	533	165	25	432	178	886	803	34	373
in	32.8	30	23.4	10.5	21	6.6	1	17	7	34.9	31.6	3.3	14.5
mm	833	762	594	267	533	168	25	432	178	886	803	34	368

## Relationship of meter pressure drop to flow rate and viscosity

With Liquid Controls' unique design, the bearing surfaces of the meter element are internally and externally subjected to the same system pressure. Due to the low pressure drop inherent to the LC meter, it is often possible to satisfactorily measure higher viscosity products through a smaller LC meter than its competitive equivalent.

Pressure drop through a meter depends on product temperature, viscosity and flow rate. When metering a liquid, the pressure drop will increase as viscosity increases. For many applications, pressure drop through an LC meter is on the order of 3 PSI for metering liquids with approximate viscosity of 30 SSU (1 centipoise). For additional pressure loss data, consult factory.

## Construction/application classes

LC steel-case PD meters are suitable for metering a broad range of products as listed below. The appropriate meter class can be used to specify a desired meter by using the table on the back page of this publication.

Class	Description	Bearing Material
1	Refined petroleum products	Ni-Resist <sup>e</sup>
2	Aviation and jet fuel	Ni-Resist <sup>e</sup>
7	Chlorinated solvents	Carbon
8	Acid pH liquids includes: nitric, phosphoric, glacial acetic acids	Carbon <sup>f</sup>
10	Liquid propane gas	Carbon
14	Crude oil	Ni-Resist
16	General solvents	Carbon
37	Sodium hydroxide solutions, high sulfur crude oil, alkaline pH liquids	Ni-Resist

<sup>e</sup> Carbon bearings are standard on some meter sizes of this class. Consult factory.

<sup>f</sup> Teflon<sup>®</sup> bearings optional on some meter sizes. Consult factory.

## Meter flow rate limit (percent of rated flow vs. viscosity)

Use the chart below to determine maximum meter flow rate relative to meter bearing material and product viscosity:

(1) determine the percent of rated capacity at which the meter will be required to operate; (2) determine product viscosity at system operating temperature; (3) plot the point on the chart where the two lines intersect; (4) determine the meter bearing material from construction/application table above and locate the corresponding slope on the chart.

If the plotted point is above the bearing material slope, you are outside the allowable pressure loss for the specified meter and bearing. You should either chose a larger meter, reduce flow rate or consider alternative bearing materials.

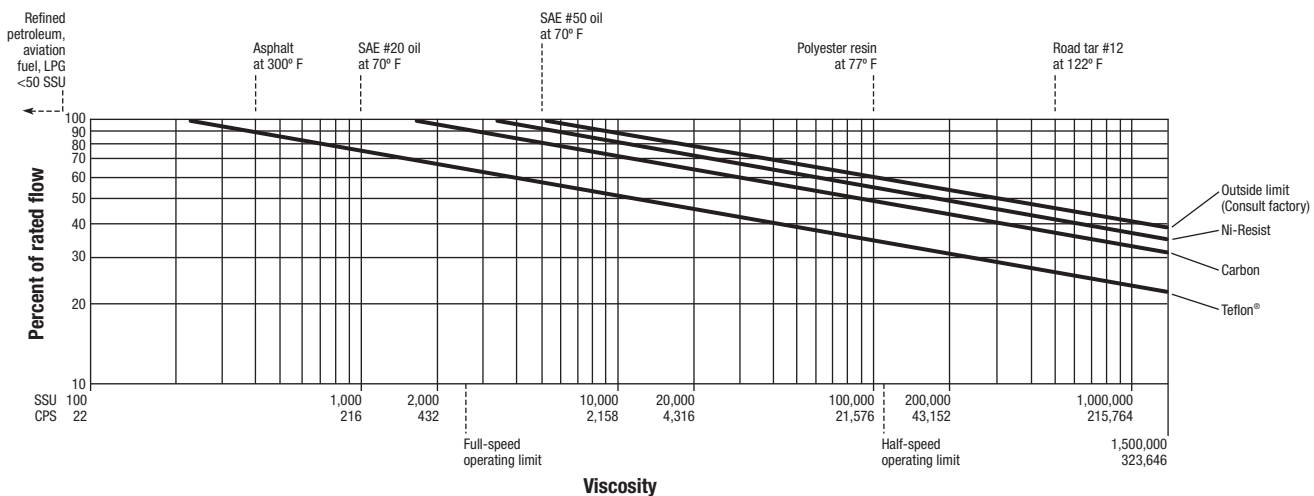

## Purchase specifications

To make certain you receive a meter with the many installation, operating and maintenance advantages of a Liquid Controls product, please include the following statement in your engineering and purchase specifications.

"Meter shall be of the positive displacement design having rotary motion without axial thrust or flow impingement. No eccentric, sliding, reciprocating or oscillating parts to induce excess liquid shear or liquid compressibility within meter element. Rotary parts to be horizontally supported on both sides by solid support bearings and rotor journals of materials compatible with product to be metered. No ball bearings, springs or cams. Rotary drive and meter adjustment output to all readout devices shall be non-cyclic without pulsation and capable of meter accuracy adjustment of 0.02% or better. Meter calibration adjustment device must be externally accessible, not requiring removal of any readout equipment for calibration or replacement. Meter measuring element shall have a minimum braking torque and shall immediately respond to product low flow movement."

## Ordering information (please refer to chart at right for LC model naming system)

Model: \_\_\_\_ - \_\_\_\_ - \_\_\_\_ - \_\_\_\_ Description: \_\_\_\_\_

Flow rates: Max. \_\_\_\_\_ Normal \_\_\_\_\_ Min. \_\_\_\_\_

Operating temperatures: Max. \_\_\_\_\_ Normal \_\_\_\_\_ Min. \_\_\_\_\_

Maximum non-shock operating pressure: \_\_\_\_\_

Maximum viscosity: \_\_\_\_\_ @ \_\_\_\_\_ (Temp°F or C)

Specific gravity: \_\_\_\_\_

Construction class: (1, 2, etc.) \_\_\_\_\_ Seal material:  Standard Buna/Viton  All Viton  All Teflon

Direction of flow:  L to R  R to L Read out:  Gallons  Liters  Pounds  Other \_\_\_\_\_

Mechanical counter and printer:  Zero/Face up  Zero/Face down  Accumulative

Strainer basket:  40M  80M  100M  Other \_\_\_\_\_

Flange size: \_\_\_\_\_ Flange type:  RF or FF ANSI  DIN  Other \_\_\_\_\_

Options: \_\_\_\_\_

\_\_\_\_\_

\_\_\_\_\_

## Product model numbering system:

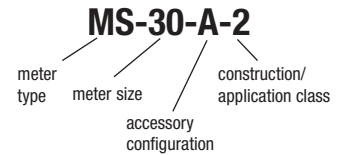

## Standard accessory configurations (A, C, I, K): MS-30 meter shown

MS/MSA-30-**A**

**A** = Meter with counter

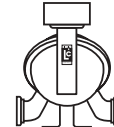

MS/MSA-30-**C**

**C** = Meter with counter, strainer and air eliminator

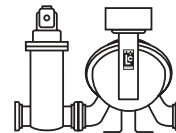

MS/MSA-30-**I**

**I** = Meter with counter, preset counter and preset valve

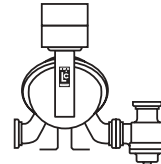

MS/MSA-30-**K**

**K** = Meter with counter, preset counter, preset valve, strainer and air eliminator

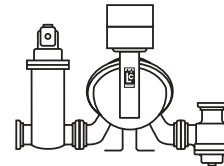

**Backed by our world-wide reputation for quality, accuracy and advanced design.**



## LIQUID CONTROLS

A Unit of IDEX Corporation  
 105 Albrecht Drive, Lake Bluff, IL 60044-2242  
 1.800.458.5262 • 847.295.1050  
 Fax: 847.295.1057  
 www.lcmeter.com

ISO 9001



DNV

CERTIFICATED FIRM  
 Certificate No. 08732

ISO 14001



DNV

CERTIFICATED FIRM  
 Certificate No. 05649

Copyright © 2003 Liquid Controls  
 Pub. 300-20 (5/03)

